

# 2025 Competition Information and Rules

In partnership with the Florida Engineering Society and  
the Cox Science Center and Aquarium



**TABLE OF CONTENTS**

---

GENERAL INFORMATION .....	3
GENERAL RULES .....	5
DROP IT!.....	7
BUILD IT.....	10
FLY IT!.....	15
THRILL IT!.....	19
CLEAN IT! .....	24
POWER IT!.....	29

## GENERAL INFORMATION

---

Engineer It! is an engineering design competition jointly presented to all students by the **Cox Science Center and Aquarium (CSCA)** and the **Florida Engineering Society (FES)**.

- **Safety** is the highest priority. Violators of safety protocol will be disqualified.
- This is an educational and fun competition for CHILDREN/STUDENTS.
- The goal of the overall event is to LEARN.
- Rules and judges attempt to be fair to all competitors – neither are perfect and people make mistakes.
- Good sportsmanship is expected from all participants, parents, and sponsors.
- Anyone that, in the opinion of the judges and science center staff, does not behave in the true spirit of the event will be disqualified.
- Any dissension with rulings by judges, which are final, may result in participant disqualification.

**Date:** Saturday, April 12, 2025

**Time:** 7:00 – 8:30 AM Check In  
9:00 AM Competition Starts  
12:00 -1:00 PM Break  
1:00 PM Competition Resumes  
3:00 PM Competition Ends  
4:00 PM Awards Ceremony

**Location:** Cox Science Center and Aquarium  
4801 Dreher Trail North  
West Palm Beach, FL 33405

**Website:** <https://www.coxsciencecenter.org/event/engineer-it>

**You may be photographed for Science Center media purposes throughout the competition. By registering to compete, you are giving photo consent. If you do not wish to be photographed, notify the staff members at the registration tent when you arrive.**

**Questions regarding the event details**, please contact the following staff member(s) from the Cox Science Center and Aquarium:

Chris Pait  
[Cpait@coxsciencecenter.org](mailto:Cpait@coxsciencecenter.org)

**Questions regarding the rules of competition**, please contact the following engineer(s) in the Florida Engineering Society Palm Beach Chapter:

Jimmy Richie, PE  
[Jimmy.Richie@wginc.com](mailto:Jimmy.Richie@wginc.com)

## Engineer It! 2025 Competition Information and Rules

### Materials:

Competitors are encouraged to use reuseable, upcycled, and recyclable materials to the extent they do not violate the rules and are safe. In that spirit, an event partner, [Resource Depot](https://www.resourcedepot.org), is offering competitors the Materials Marketplace coupon below!



The coupon is enclosed in a dashed green border. On the left is a photograph of two women in a store, one handing a yellow bin to the other. To the right of the photo is the Resource Depot logo (two circular arrows) and the text 'RESOURCE DEPOT turning waste into wonder'. Further right is the address '2508 Florida Avenue | West Palm Beach | 33401' and website 'WWW.RESOURCEDEPOT.ORG | 561-882-0090'. Below this is the main offer: 'FILL A BIN WITH SUPPLIES FOR ENGINEER IT!' in large green letters. Underneath, it says 'Resource Depot is proud to support the COX SCIENCE CENTER AND AQUARIUM for a greener event.' followed by 'This certificate entitles the bearer to fill one 6-gallon bin from our Materials Marketplace.' A green banner at the bottom of the coupon reads 'Our inventory of reusables changes daily, so you never know what treasures you'll find!'. At the very bottom, in smaller text, it says 'Present certificate at our check-in desk. Valid only during shopping hours. Check our website for most current hours. One coupon per student. No cash value. Cannot be combined with other offers. Expires April 15, 2025.'

Similarly, competitors are discouraged from using commercial models, kits, and similar pre-designed materials; however, the rules of each event may allow or prohibit commercial models.

Please submit questions about materials as soon as possible during your design process.

## **GENERAL RULES**

---

1. The competition is open to students in elementary, middle and high school levels.
2. Students may participate individually or in teams—maximum of 4 students per team for Thrill It, maximum of 6 students per team for Power It, and maximum of 2 students per team for other events that allow teams. Refer to the rules of each event.
3. Students must register online at <https://www.coxsciencecenter.org/event/engineer-it>.
4. Students and their materials and pre-assembled entries, as defined in each event rule section, must be present and complete at the Science Center at the designated check-in time on the day of competition.
5. Students registered for Thrill It! are encouraged to arrive as early as 7:00 AM to drop off roller coasters. CSCA/FES staff will regulate the maximum number of people, including teachers, parents, coaches, judges, and staff inside the room at one time. At the discretion of CSCA/FES, additional restrictions may be applied for safety and efficiency. Students will have five minutes to place their roller coasters on the tables and make adjustments. Drop-off must be complete by 8:50 AM; otherwise, the student/team must wait until their scheduled time of competition to drop off the roller coaster.
6. Entries must be clearly marked with the name(s) of the entrant(s) and meet construction specifications.
7. Only students are allowed in the designated qualification, competition, and scoring areas. Exceptions shall be made for students requiring special assistance.
8. Parents and teachers shall not modify or assist with entries—verbally or physically—from the time the students enter the qualification areas, progress through the competition areas, and exit the scoring areas. Exceptions shall be made for students requiring special assistance.
9. All questions and disputes must be brought to the attention of CSCA/FES staff on the day of the event and will not be considered thereafter.
10. Video or audio recording of complaint/interaction with judges will not be tolerated and will cause dismissal from the event.
11. **All decisions of the judges are final.**



**Drop it**

## **DROP IT!**

---

### **ENGINEERING DESIGN CHALLENGE**

Design and build a shipping container that will prevent an uncooked egg from breaking when dropped from a height of 50 feet.

### **CONSTRUCTION SPECIFICATIONS**

#### 1. MATERIALS

- A. Not permitted: parachutes, pool noodles, balloons, fins, brims (including an upside-down “witch hat”) propellers (of any type), drones, foam packing peanuts, Styrofoam, or inflatable material (i.e. inflatable foam, bubble wrap, air pillow packing material, inflated plastic bag etc.) of any kind.
- B. Commercial kits or pre-made designs may not be used.
- C. Eggs will be supplied (Grade A large chicken eggs).

#### 2. CONSTRUCTION

- A. The maximum dimensions of the container shall be 8" x 8" x 8".
- B. The entire container must be able to pass through an 8" x 8" square aperture on all three axes (8" cubed dimension) to qualify.

### **TESTING AND JUDGING**

- 1. A maximum of two people per team and one container per team will be accepted.
- 2. Only one attempt will be allowed for each entry.  
Note: It is recommended that students test and redesign their container prior to competition day. Practice the iterative process of engineering.
- 3. Students shall line up in the qualification area. Each container will be inspected, measured, and weighed, after which no further adjustments other than closure will be permitted. All materials required to close the container must be presented to the judges for inspection, measurement, and weight.
- 4. One egg will be provided to each contestant. The container must be closed in the presence of the judges. No further modifications are permitted.
- 5. Students shall line up in the competition area with their closed containers.
- 6. The container will be dropped from a height of 50 feet.
- 7. A successful drop is:
  - a. The egg does not show any signs of cracking. A cracked egg is a broken egg.

## Engineer It! 2025 Competition Information and Rules

- b. The egg remains in the container throughout the free-fall, impact, and after impact.
  - c. Final discretion resides with judges.
8. After the drop, the students shall line up in the scoring area with their closed containers. When directed by the judges, students shall remove the egg from the container for inspection by the judges.
  9. Each egg container that passes the drop test will be weighed without the egg and with all the material that was removed to open the container and remove the egg.
  10. The winning entry will be determined by the container that weighs the least and successfully completes the drop, without the egg breaking/displaying any cracks.



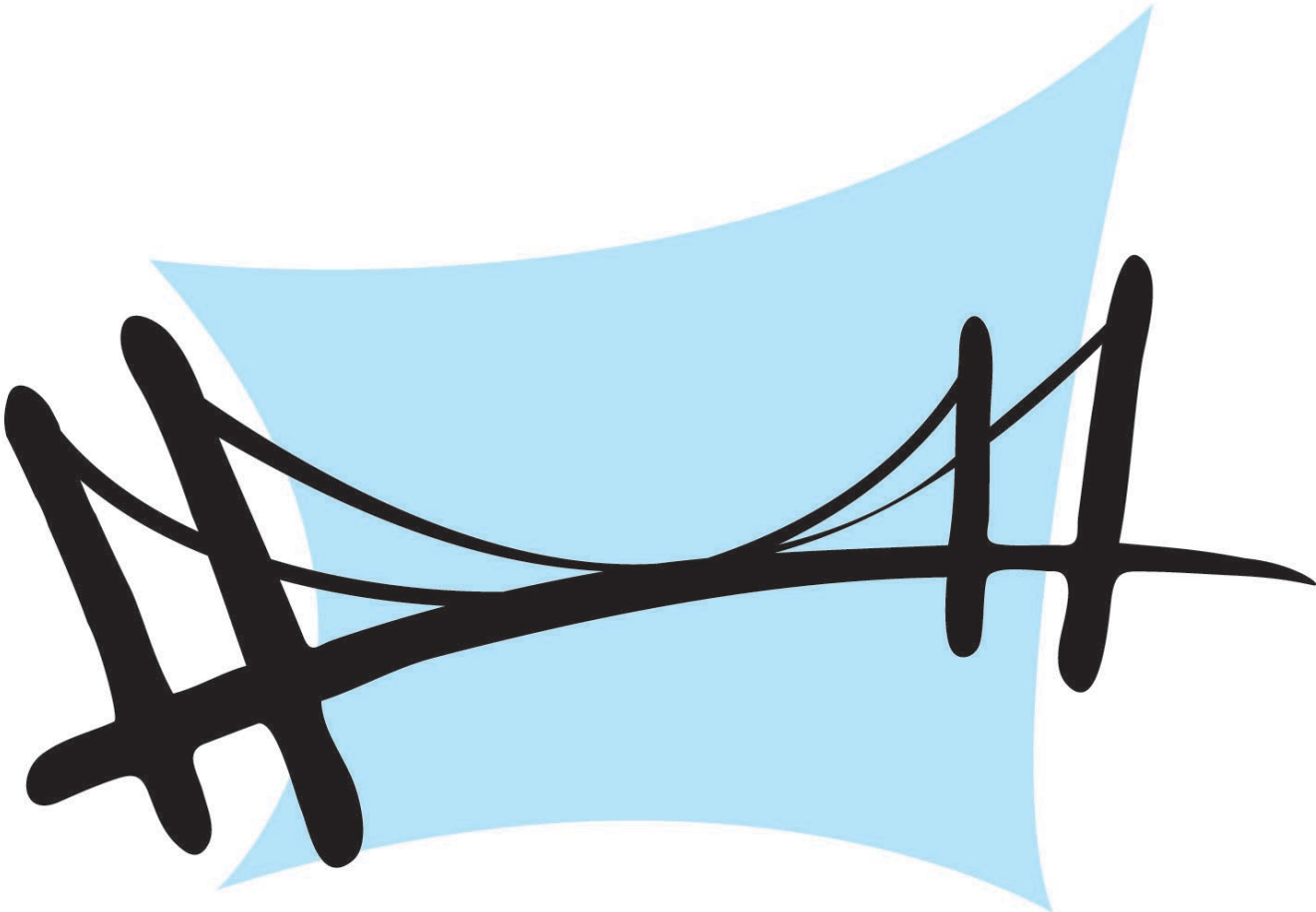

**Build it**

## BUILD IT

---

### ENGINEERING DESIGN CHALLENGE

Design and construct the lightest truss-frame bridge capable of supporting the greatest weight.

### CONSTRUCTION SPECIFICATIONS

#### 1. MATERIALS

- A. Bridges must be constructed of balsa wood and glue. No other size or species of wood or material type of connections are permitted. Participants must supply their own wood and glue. Bridges shall not be coated in glue, paint or stain.
- B. Truss-frame members must be a maximum of 1/8" wide x 1/8" high and equal to or greater than 2" in length. Members may be notched or cut in any manner. Chords may be continuous for a portion of or the entire span.

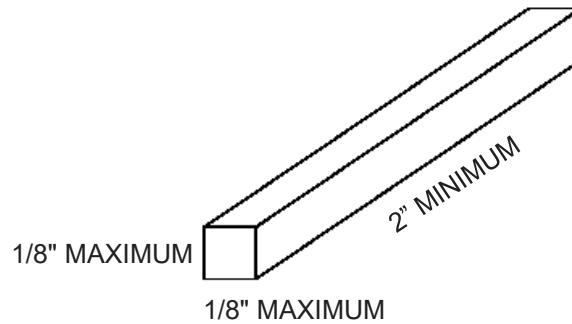

- C. Single member construction only. Lamination of any kind or layering of wood in any direction will not be permitted.

#### 2. CONSTRUCTION

- A. Members and connections may overlap a maximum of 1/8".

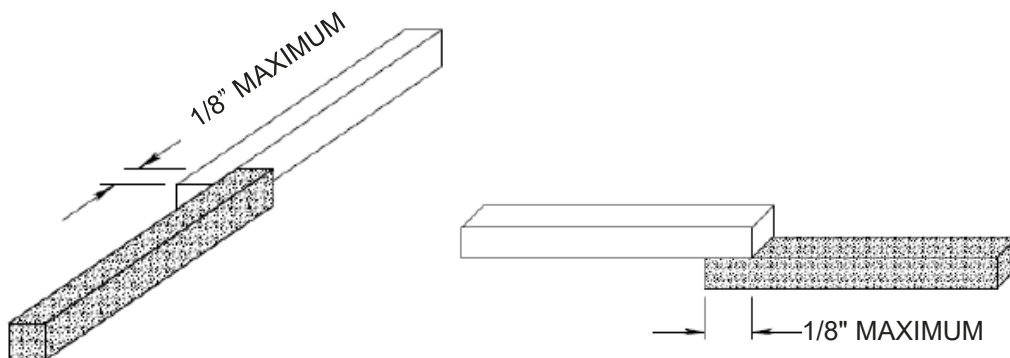

B. Connections must be a minimum of 2" on-center apart from each other.

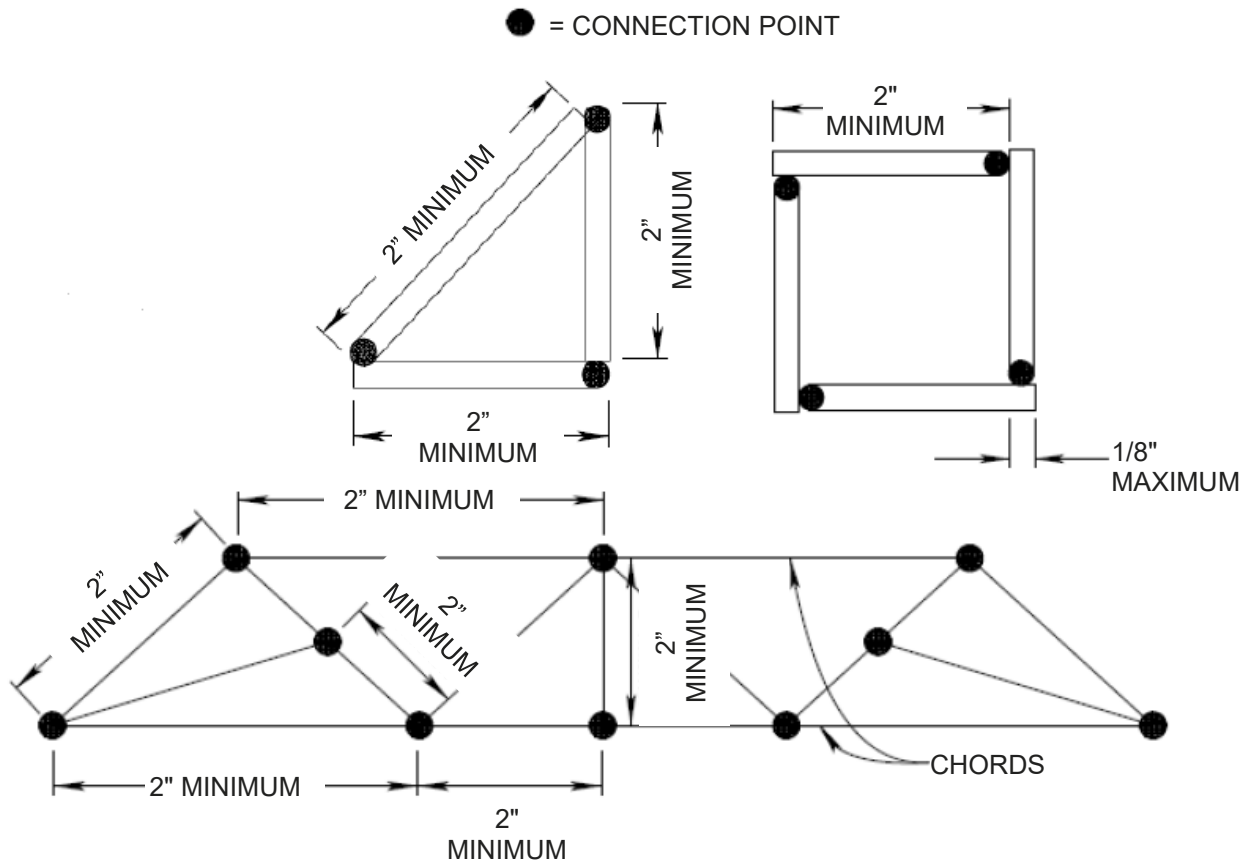

C. The length of the bridge must be a maximum of 18". Bridges will be loaded across a clear span of 16" with a maximum of 1" bearing at each end.

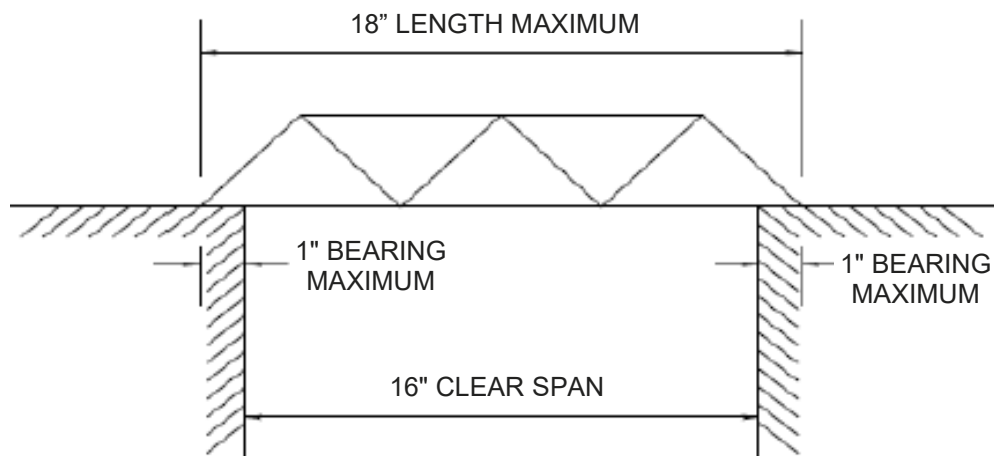

D. The height and width of the bridge must be a maximum of 5" wide x 5" high. The entire

bridge must pass through a square aperture 5" wide and 5" high to qualify.

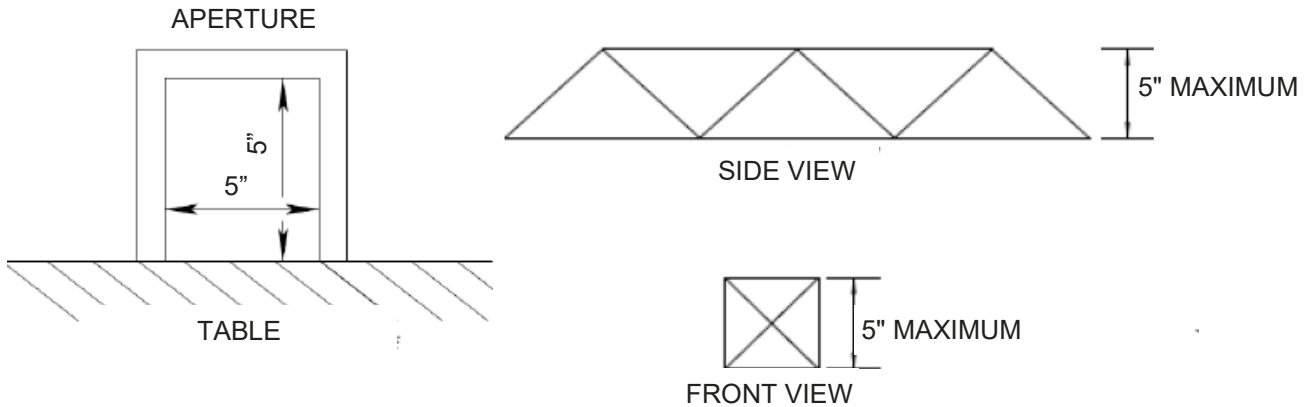

E. Example trusses (research additional types):

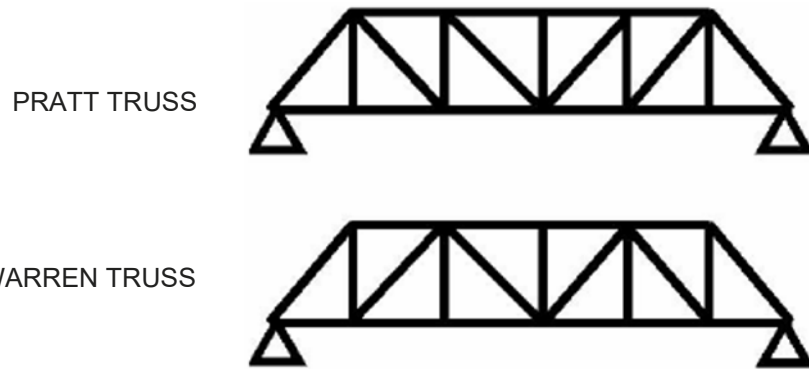

### TESTING AND JUDGING

- A. Only one entry per person/team.
- B. Each bridge will be visually inspected, measured, and weighed. Once the bridge is qualified, no further adjustments will be permitted.
- C. Each bridge will be centered on the supports.
- D. A loading bar, approximately 1" wide, will be placed across the mid-point of the top of the bridge to apply the test load.

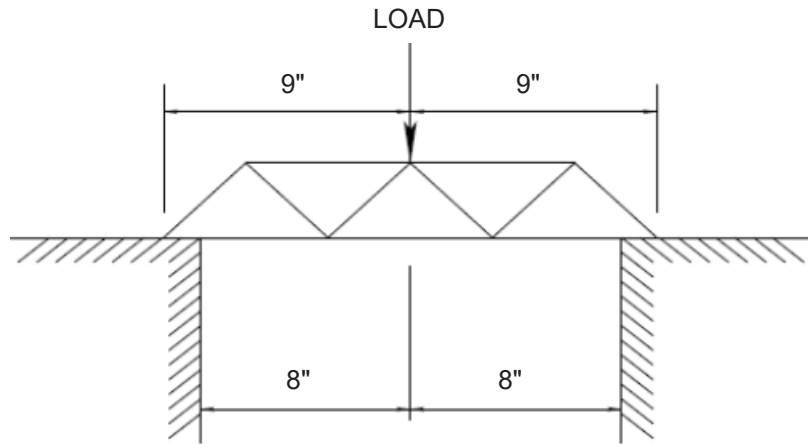

- E. The initial load will be an empty plastic 5-gallon bucket (or equivalent) attached to the ends of the loading bar with rope. Further loading will be applied by slowly pouring sand into the bucket until failure. Bridges that support a full load of sand will have additional weights placed into the bucket until failure. Failure is defined as the moment when the bucket touches the ground.
- F. After failure, the loaded bucket will be weighed.
- G. Winners will be determined by the highest efficiency, E.

$$E = \frac{\text{weight of the load}}{\text{weight of the bridge}}$$



**Fly it**

## **FLY IT!**

---

### **ENGINEERING DESIGN CHALLENGE**

Design and build a paper airplane that will fly the longest distance.

### **CONSTRUCTION SPECIFICATIONS**

#### 1. MATERIALS

- A. Each entrant will receive the following:
  - 1) 1 sheet of 8 ½" x 11" paper
  - 2) 1 paper clip
- B. The plane **MUST** be made at the event.
- C. No staples, adhesives or tape can be used.
- D. No cutting of paper is allowed. Folded planes only.

#### 2. CONSTRUCTION

- A. When the group arrives at the Fly It event area, each entrant will receive the materials. Upon receiving the materials, the entrants must build their plane within the allotted time and location, have it inspected for qualification by the judges, and then wait in line for the flight. Changes may not be made after inspection. Only students will be allowed in the construction area.
- B. The sheet of paper may only be folded to construct the desired shape. Rolls, tears, cuts, holes or crumples are not allowed.
- C. The provided paper clip must be fastened onto the plane.

(space intentionally left blank)

- D. Planes must have wings with a length equal to or greater than the height of the body (fuselage).

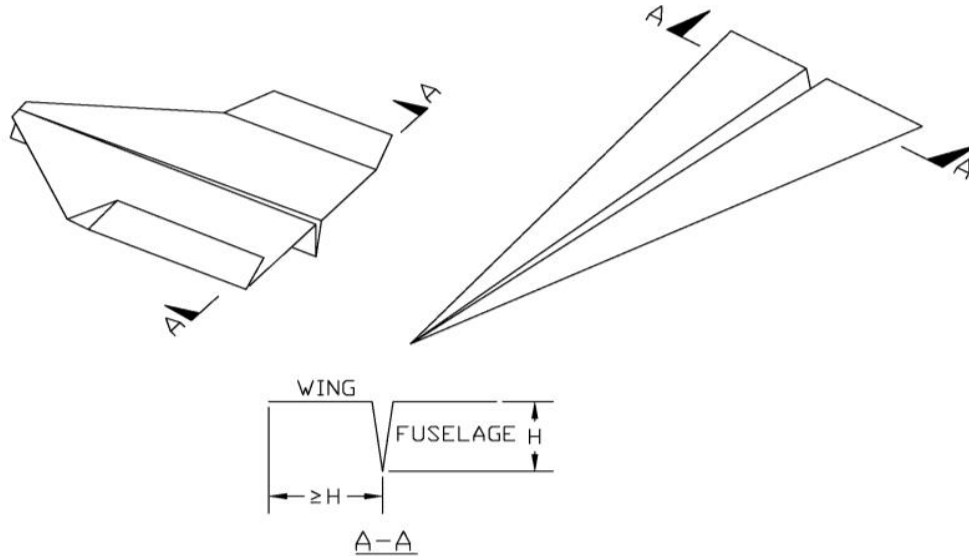

- E. Planes must be ready for inspection at the start of each group's air race.

**No test flights are allowed.**

- F. Upon inspection, if the plane is found to be in violation of any of the Construction Specifications the plane will be disqualified and prohibited from flying and the student will forfeit their entry in this event.

- G. Examples of acceptable paper airplanes (not all inclusive):



**Figure 1: Dart**

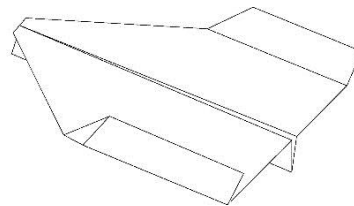

**Figure 2: Glider**

## TESTING AND JUDGING

1. Only one entry (plane) per person will be accepted.
2. Only one attempt to fly will be allowed for each plane.



## Engineer It! 2025 Competition Information and Rules

3. The contestant must fly the plane standing behind the designated launch line. A contestant passing or stepping over the launch line will be disqualified, and their plane will not be scored.
4. Judge(s) have discretion over the size of the legal landing zone. Boundaries will be marked in advance. The entire plane must rest within the landing zone. A plane landing outside the designated landing zone will not be measured or scored.
5. Distance will be measured from the front of the launch line to the point where the plane first touches any object (ground, chair, etc.).
6. The judge(s) will measure and record the flight distance.
7. Winners will be determined by the longest flight distance.



**Thrill it**

## **THRILL IT!**

---

### **ENGINEERING DESIGN CHALLENGE**

Roller coasters are called "gravity rides" for a good reason: once the coaster has been dragged to the top of the first hill and released, it is the force of gravity that keeps the coaster going all the way back to the station platform at the end of the ride. As the coaster goes through its twists, turns, rolls, and loops, it gains and loses its initial potential energy (supplied by dragging it up the first hill). Energy changes from potential into kinetic energy and back into potential energy. Since some of this initial energy is lost due to friction, the roller coaster can never rise as high as the first hill. The roller coaster you will design is also a "gravity ride".

In the "Spirit of the Competition," the key ingredients are creativity and application of science principles. Doing a great job is encouraged over spending lots of money to complete the project.

### **DOCUMENTATION**

Each team must attach a 3" x 5" index card to the roller coaster.

1. The front of the card should include:
  - A. Name of the Roller Coaster
  - B. Grade Level (K-5, 6-8, or 9-12)
2. The back of the card (not showing) should include:
  - A. Team Name
  - B. Members of the Team with grade level and School Name (if applicable)

### **CONSTRUCTION SPECIFICATIONS**

#### **1. MATERIALS**

- A. Approved materials include wood, wire, string, twine, dowels, toothpicks, cardboard, construction paper, lightweight metals (including nuts and bolts), glue, tape, and other low-cost items.
- B. Commercial roller coaster kits, including paper kits, will result in up to a 25-point deduction (see Deductions below).
- C. The use of an inclined plane with bumpers to create a "pinball" like structure is prohibited. All coasters must have a track on which the ball rolls.
- D. The coaster must be designed for a steel ball or glass marble that is 1 cm (~1/2") in diameter or greater. Each team must supply their own steel ball or glass marble.
- E. Magnets, electricity, springs, and other forms of energy may not be used – this is a "gravity ride" only. These other sources of energy can be used for aesthetics (i.e., background lighting). No electricity is provided in the contest area.

## 2. CONSTRUCTION

- A. The base, including all shims, must fit within a 30 cm x 75 cm rectangular footprint (image below).
- B. The entire roller coaster must fit within a 30 cm wide x 75 cm long x 100 cm high, rectangular box (image below), including all decorations.

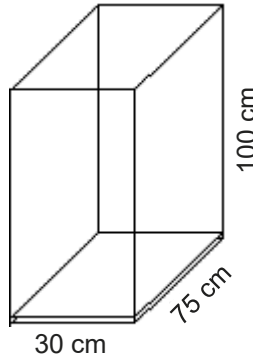

- C. The steel ball or glass marble when released from the top of the first hill will travel through the entire ride and arrive at the bottom loading platform. Note: for this contest, you will raise the steel ball or glass marble by hand from the loading platform to the top of the first hill to start the ride.
- D. The starting and ending positions must be clearly marked.
- E. Each team can have a maximum of 4 students.
- F. The decision of the judges is final. Any coaster that violates the rules above or the spirit of the competition will be disqualified.

## TESTING AND JUDGING

### 1. Run Time

**0-50 points** will be awarded for run time. Each team will be entitled to three runs. The longest run time from start to finish positions will be the official time for that team. The time of a run that fails to make it from start to finish positions will not be recorded and will count as one of the three runs allowed.

Example: Assume the maximum time was 15 seconds and your coaster took 9 seconds.

$$\text{Points} = 50 \text{ points} \times (\text{your time} / \text{maximum time})$$

$$\text{Points} = 50 \text{ points} \times (9 \text{ sec} / 15 \text{ sec}) = \underline{30 \text{ points}}$$

The points awarded for time will be based on the maximum run time within the grade level (K-5, 6-8 or 9-12).

### 2. Technical Merit

A. Track Openness

**0-15 points** may be awarded for degree of openness of track.

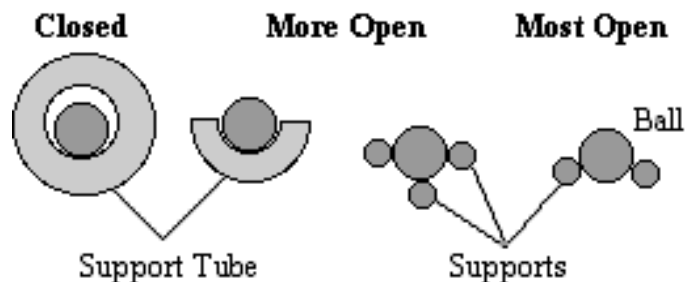

B. Performance

**0-10 points** may be awarded based on the performance of the roller coaster with the steel ball or glass marble ending in a designated area or container during each run.

Technical merit points will be awarded based on the following rubric:

Track Openness	Mostly closed = 0	>25% open = 5 pts	>50% open = 10 pts	>80% open = 15 pts
Performance	Ball does not end in designated area=0 points	Ball ends in designated area during 1 run=3 points	Ball ends in designated area during 2 runs=6 points	Ball ends in designated area during 3 runs=10 points

3. Theme (creativity)

**0-10 points** may be awarded based on the theme of the roller coaster.

Theme	No theme = 0	Theme but little follow through = 3 pts	Theme throughout ride = 6 pts	Theme well done throughout = 10 pts
-------	--------------	---	-------------------------------	-------------------------------------

4. Bonus points for technical merit will be awarded for the following:

**5 points per vertical loop.** Vertical loop is defined as any time the "rider" is upside down on a loop of track that is within 10° of vertical (see illustration). If the vertical loop is a portion of a corkscrew (helix), it counts as a vertical loop. Horizontal loops do not add bonus points.

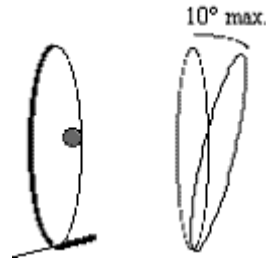

Bonus Points for technical merit will be awarded based on the following rubric:

Vertical Loops	1 = 5 pts	2 = 10 pts	3 = 15 pts	4 = 20 pts
----------------	-----------	------------	------------	------------

5. Deductions

Use of commercial roller coaster kits, including paper kits, will result in a deduction according to the following rubric:

Use of Commercial or Paper Kits	Elementary = -15 pts	Middle = -20 pts	High = -25 pts
---------------------------------	----------------------	------------------	----------------



**Clean it**

## **CLEAN IT!**

---

**IMPORTANT: Please note that water filtered by contestants, while it may look clean, is not safe for human consumption. DO NOT DRINK!**

### **ENGINEERING DESIGN CHALLENGE**

Design, build, and test a water filter to clean non-toxic contaminated water (water mixed with potting soil) and produce the lowest turbidity reading (measure of liquid clarity).

### **CONSTRUCTION SPECIFICATIONS**

#### **1. MATERIALS**

- A. The filter must consist of two chambers: the Sump (where filtered water collects) and Filter Bed (where water is filtered). Each chamber shall be built from a clear 2-liter plastic bottle (see Diagram 1). Both the Sump and Filter Bed must be clear and clearly visible. Tinted plastic is not allowed. Bottle labels must be removed.
- B. The filter shall consist of typical household items, food-grade items such as bread, rice, oatmeal, and crackers, and/or natural materials such as sand, rocks (less than 0.5 inches in diameter), charcoal, straw, wood chips, cotton, clay, and silt. Contestants are allowed to use additional materials, but they shall not be commercial materials such as chemicals or manufactured filters.
- C. Each individual or 2-person team will receive the following:
  - 1. One (1) basket style paper coffee filter or plastic net/screen—to be determined, but the same item will be given to all contestants.
  - 2. One (1) rubber band;
  - 3. One (1) collection cup—clear 9-ounce cup or similar;
  - 4. One (1) transfer cup—clear 16-ounce cup or similar; and
  - 5. One (1) 16-ounce bottle of water mixed with 1/3 cup of potting soil.
- D. Each individual or 2-person team must bring the following:
  - 1. Pre-cut clear plastic 2-liter bottles; and
  - 2. Filter media in separate clear containers or bags clearly labeled with the type of material (e.g., “sand”).

#### **1. CONSTRUCTION**

- A. When the group arrives to the Clean It event area, each contestant/team will receive the items in 1.C above. Please keep all items until the competition is complete and do not damage bottles or cups.



## Engineer It! 2025 Competition Information and Rules

- B. The filter must consist of two chambers: the Sump (where filtered water collects) and Filter Bed (where water is filtered). Each chamber shall be built from a clear 2-liter plastic bottle (see Diagram 1).
  1. Cut a clear 2-liter plastic bottle near the mid-point before the event. Please use caution when using scissors and knives. Tools are not provided at the event. The organizers will not assume any liability for personal injury or damage.
  2. The bottom section of the pre-cut 2-clear liter bottle will be the sump, the top section will be used to build the filter bed.
  3. To build the filter bed, take the top section of the pre-cut clear 2-liter plastic bottle and attach the coffee filter to the cap end with the rubber band.
  4. Insert the filter bed cap end into the sump. The sump and filter bed should be free-standing and need no outside support to remain upright in operation (see Diagram 2).
- C. The filter bed shall consist of one to four layers of filter media.
- D. The total thickness of the filter media must be a maximum of five inches (5") with each layer at least one inch (1") thick.
- E. Each filter layer in the sump must be clearly labeled with the type of material (e.g., "SAND") printed in black permanent marker.
- F. The filter bed, sump and collection cup must be labeled with the contestant's full name printed in black permanent marker.
- G. Contestants are asked to be considerate and clean up after themselves. Please dispose of garbage and filters properly in trash cans.

### TESTING AND JUDGING

- A. Only one entry per person/team will be accepted. A maximum of two people per team will be accepted.
- B. Contestants will line up to present their filter bed, sump, and materials to the judges for inspection and approval before assembling the filter. Materials which are not suitable may not be used. See MATERIALS, Section B. After inspection, contestants shall take their places at the tables.
- C. Contestants will have 15 minutes to assemble the filter bed and filter the contaminated water in front of the judges. Contestants will receive a countdown and signal to begin assembling. Judges will start the timer. Judges will notify contestants of the time remaining at one-minute intervals and a final 10-second countdown. At the end of fifteen minutes, judges will signal "stop!" and contestants must remove their hands from the filters and place all items on the table.

## Engineer It! 2025 Competition Information and Rules

- D. Contestants may attempt as many filtrations as time permits but must complete the final pour into the filter bed before time expires. For multiple filtrations, pour all contaminated water from the sump into the empty transfer cup and place the filter bed back into the empty sump. Pour all contaminated water from the transfer cup back into the filter for the next filtration. The transfer cup must be emptied for each filtration. Spilled water may not be returned to the filter bed, sump, transfer cup or collection cup. Contestant shall not attempt to settle contaminants to the bottom of the sump or cup or skim contaminants from the top of the water.
- E. After filtration is complete, judges will promptly direct contestants to remove their filters from the sump and pour the filtered water into the collection cup. Filtered water not poured into the collection cup must remain in the sump. After this step, contact with the filtered water in the collection cup or sump is prohibited and will disqualify the contestant.
- F. Contestants must produce at least three ounces and a minimum depth of two inches (2") of filtered water in the collection cup to be tested.
- G. Judges will measure and record the total volume of filtered water using a graduated cylinder or equal.
- H. Judges will measure and record turbidity using a Hach 2100P Portable Turbidity Meter, or similar equipment, and reserve the right to use an alternative method if necessary. The same equipment and method will be used to the greatest extent possible. At the judges' discretion, each contestant will pour their filtered water into the original 16-ounce bottle, write their name on the bottle, and give it to the judges for testing after the competition.
- I. Scores will be based on the turbidity reading with the lowest reading being the best/top score. If tied, the filter that produces the larger volume of water receives the higher rank.

Tests at home and school:

**Newspaper Test:** Place the collection cup in front or on top of a newspaper article and look down. If the large black print letters of the headline can be read, the water is less than 30 JTU (Jackson Turbidity Units).

**Secchi Disk Test:** Place the collection cup in front of the Secchi disks below (black and white circles) and look horizontally through the cup to the chart. Match the shade of circle seen through the water with the water in the collection cup.

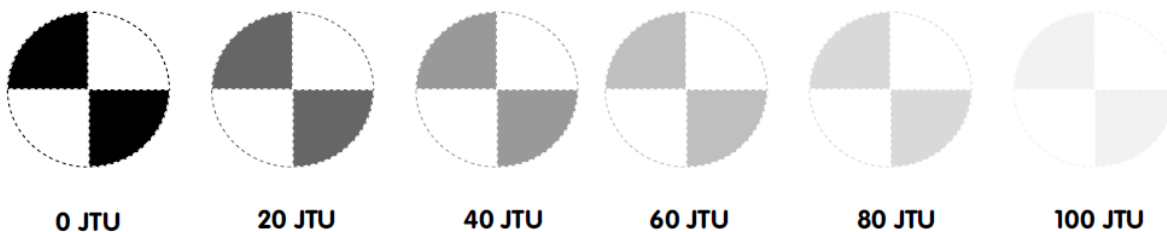

Diagram 1 - Chamber Diagram

Two clear plastic 2-liter bottles: one with its top cut off (sump) and one with the bottom cut off (filter bed).

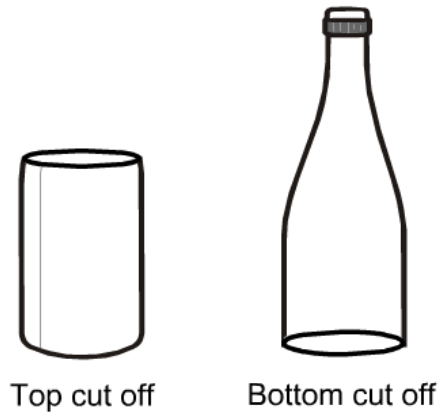
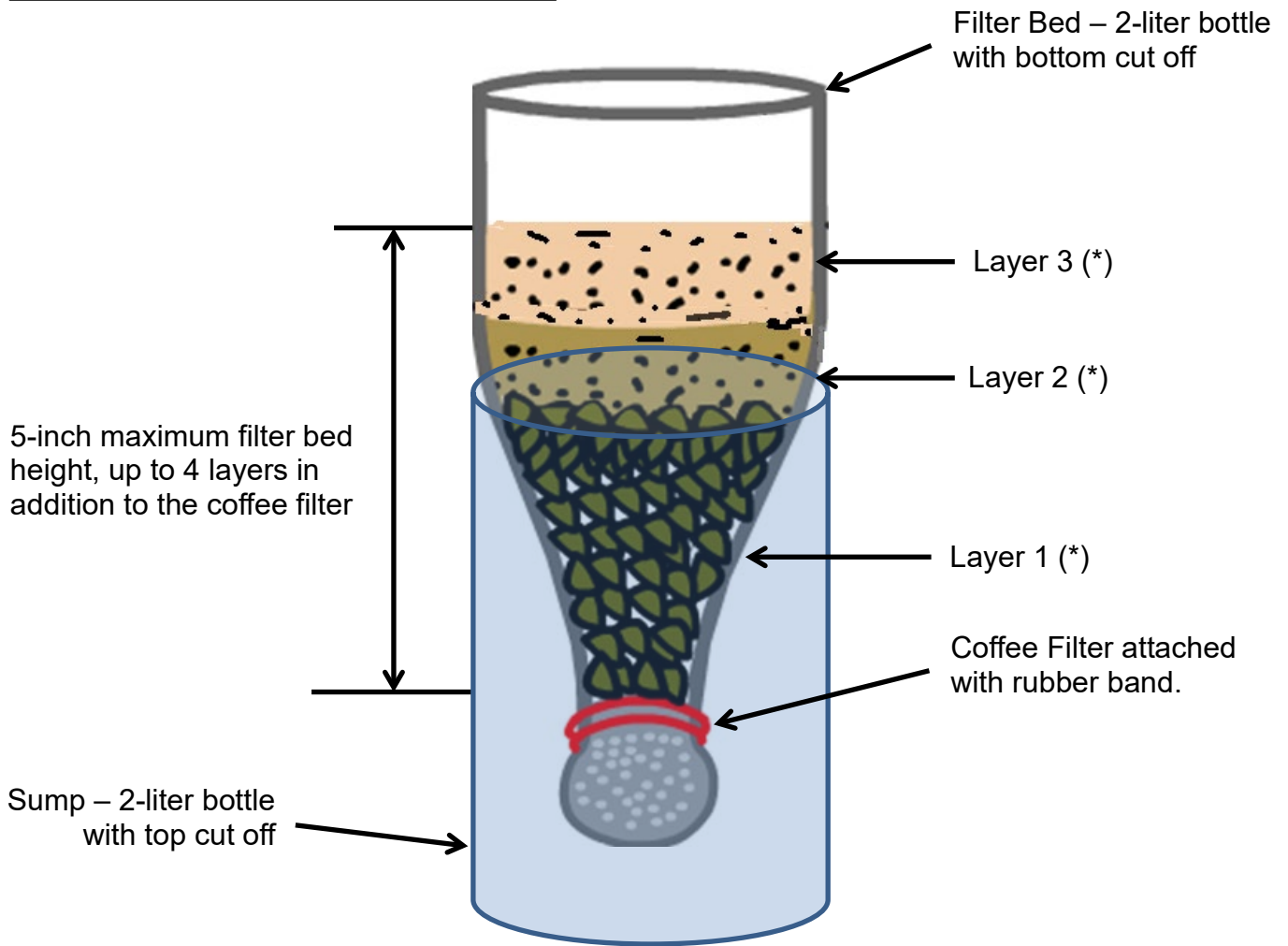
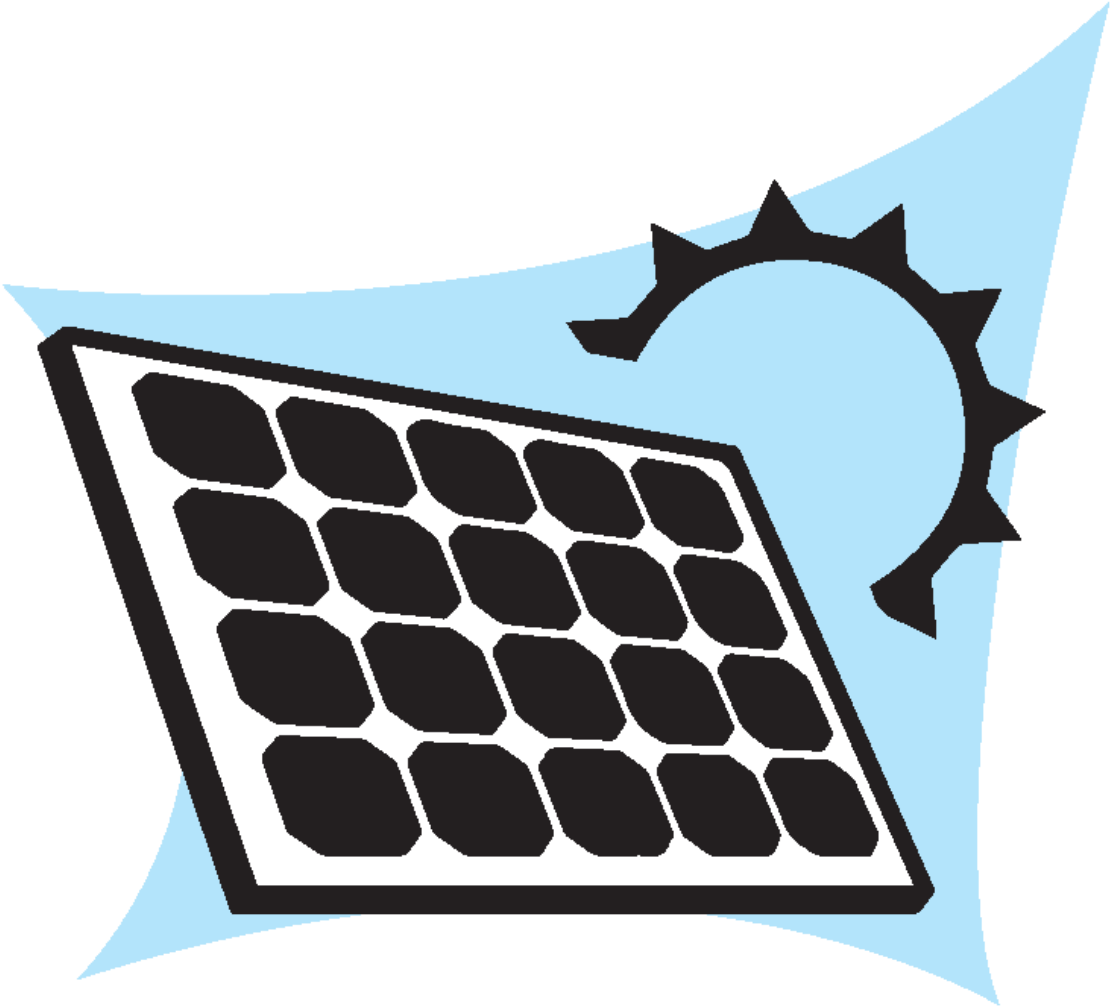

Diagram 2 - Filter Diagram



(\*) Each layer must be labeled (e.g., "sand"). Minimum layer thickness = 1 inch.



**Power it**

## **POWER IT!**

---

### **ENGINEERING DESIGN CHALLENGE**

Design and build watercraft that will run on photovoltaic panel power when placed in the water on a sunny day. The individual or team travelling the most distance with their boat in similar sunlight conditions will be the winner. A standard 3-12V DC motor and a standard small Photo-Voltaic (PV) panel will be provided for use to supply the motor in the design. The contestant will also be provided with several optional construction components also supplied by the Science Center upon your registration for the event. The solar boats will be raced against other boats in lanes on a small shallow pool. The challenge is to design and fabricate the watercraft vessel that will travel furthest when placed in a rectangular pool in direct sunlight in the ambient sun and wind conditions.

### **RULES**

Entries: Limited to 60 teams consisting of from 1 to 6 students per team.

Equipment supplied to contestants upon registration: A standardized DC motor and Photo-Voltaic (PV) panel set which are required for use. Also, some build supplies offered as optional for use by the Cox Science Center and Aquarium (CSCA) will include a metal shaft extension, plastic shaft couplings, a plastic propeller, a motor mount, and some additional wire. *Separate age-appropriate kits will be available for 3 age categories Elementary, middle, and HS level contestants.*

Contestants will design and construct at home the motorized vessel powered by the standard PV panels and DC motor provided by the CSCA. No stored energy (battery or rubber band) is allowed for the race.

The race-course lanes will be oriented generally North to South and will have rigid lane boundary lines about 12 inches wide. One pre-declared competitor per team will be allowed to adjust the boat during operation but cannot aid its speed or distance. No competitor may hinder the progress of another boat. Once the boat reaches the end wall of the pool the boat should be manually reversed and allowed to travel back and forth until the time runs out. The total distance covered, recorded in total feet covered, is the score. Each team is allowed 2 each, 5-minute tries. The best of the 2 tries will be used to create a heat final score to be recorded by the judging staff on the time of the heat.

Due to variability of sun and wind conditions, multiple competitive heats will be run to select a winner. The number of heats will be determined once the teams are registered on the day of the race. In the event of insufficient sunlight during the contest day, each team will be provided with equivalent small 3V DC batteries which will clip onto the exposed wires and power the boats.

### **CONSTRUCTION SPECIFICATIONS**

All boats must meet the following requirements:

# Engineer It! 2025 Competition Information and Rules

1. MATERIALS- supplied to registered contestant(s) prior to build
  - A. One kit provided per entry (see Figure 1)

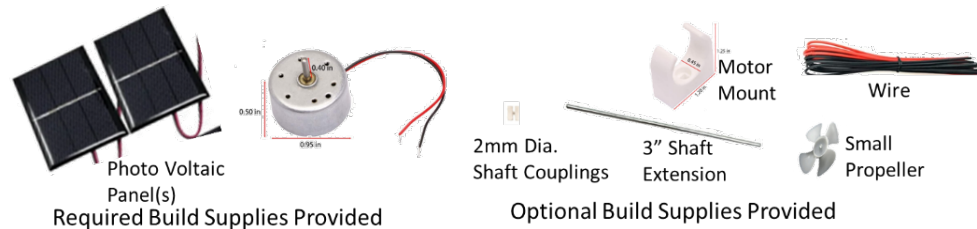
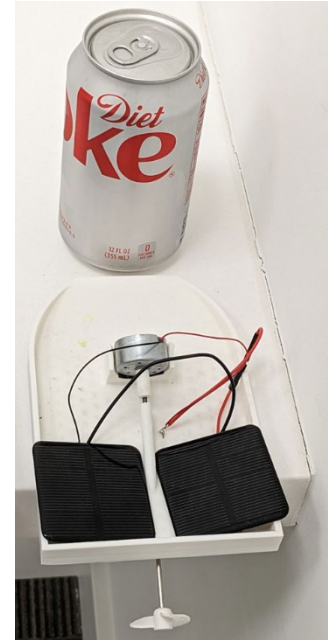

**Figure 1 Supplied items, PV Panels, DC motor, shaft, coupling, polymer propeller, motor mount, metal drive shaft, and wire**

- B. The supplied DC motor has approximate dimension of 1.3 inches diameter by 0.75 inches long. The motor shaft is 0.1 inches diameter. This shaft fits into the plastic propeller and coupling provided. The thin wire leads are several inches long. **This DC motor and PV panel(s) provided are the only power source allowed.**
    - C. *Supplied kits are age level appropriate with more design and fabrication being required for the older competitors.*

2. MATERIALS - to be secured by the contestant

- A. Safety – In design and building the project there are several potential hazards to be carefully regarded. Burn caution should be taken while soldering electrical contact connections, during build or repair. Care should be taken when using sharp cutting tools such as exacto knives. Because the voltage (<3V) and power (<1W) are very low there is no risk with the electrical power from the PV panels or motor.
  - B. Boat hull, propeller, and shaft materials can come from typical household materials or may be fabricated out of polymers by 3-D printing. The materials of construction may be from sustainable materials or recycled waste. Materials such as paper, cardboard, and cloth can be molded reinforcement for composite laminate structure. And wood, plastic or aluminum foil can be formed into acceptable vessels. Figure 2 shows a simple flat bottom hull design.
  - C. 3-D printed boats **are allowed** to be used. However, 3-D printed polymers are not necessarily waterproof without a coating or do they make the lightest weight construction.



**Figure 2 Flat-bottom PV boat design**

- D. A wide range of materials and approaches can be considered for construction. Figure 3 shows an enclosed design having the motor and PV panel inside the floating container.

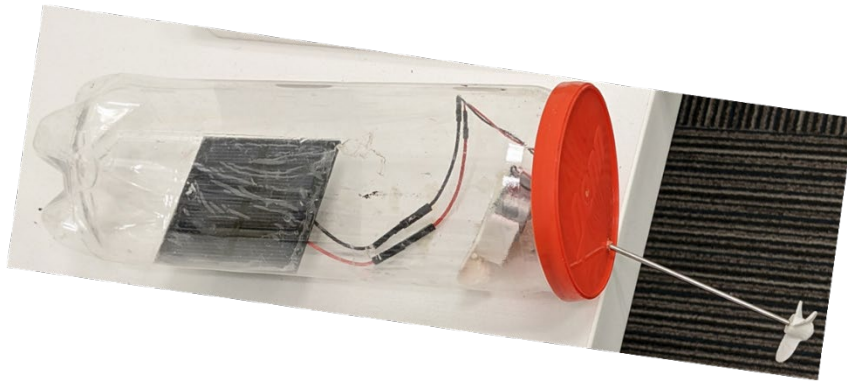

**Figure 3 Clear Plastic tube with motor and PV cell inside**

- E. The provided propeller, shaft, and coupling are optional for use and helpful to make a functioning solar boat. It is expected that improvements will need to be made to the propeller to achieve a winning design. Figure 4 depicts polymer props and couplings designed to connect the motor shaft to an extension rod.

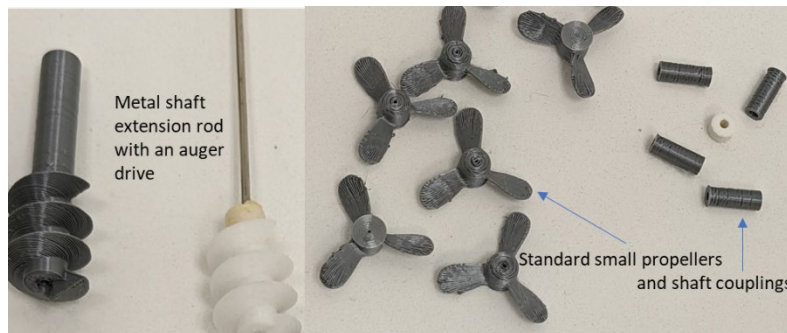
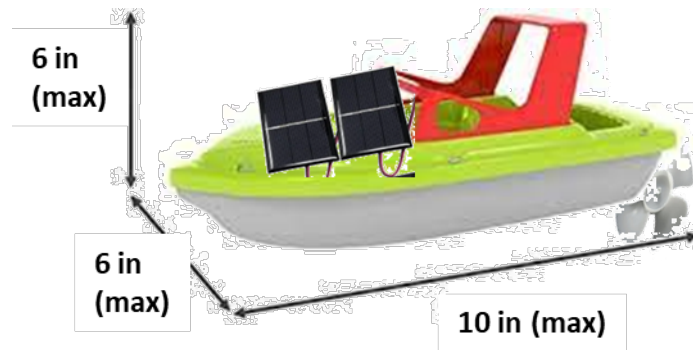

**Figure 4 Potential drive elements for connection to motor**

- F. Some repair materials such as wire, hot glue, or superglue may be available in limited quantities. Test support materials should be considered.
- G. Water-proof design- Electrical connections are generally a concern due to water contact and mechanical pulling. The thin wires and small motors have shown tolerance to some water immersion, but the wire joints are fragile and may need reinforcement protection by securing with glue or tape.
- H. Access to soldering equipment is not needed but very helpful for repair and alternative designs. Any soldering activity should be monitored by adult supervision for safety and quality reasons.

### 3. DESIGN AND CONSTRUCTION

- A. Dimensions - The maximum length, width, and height of the assembled boat shall be 10 inches, 6 inches and 6 inches respectively as shown in Figure 5.



**Figure 5 Solar boat dimension limits**

- B. The supplied motor has approximate dimensions of 1.0 inches diameter by 0.5 inches long. The motor shaft is 0.1 inches diameter. This shaft fits into the plastic coupling provided. The wire leads are several inches long. This motor is the only DC motor allowed as shown in Figure 6.

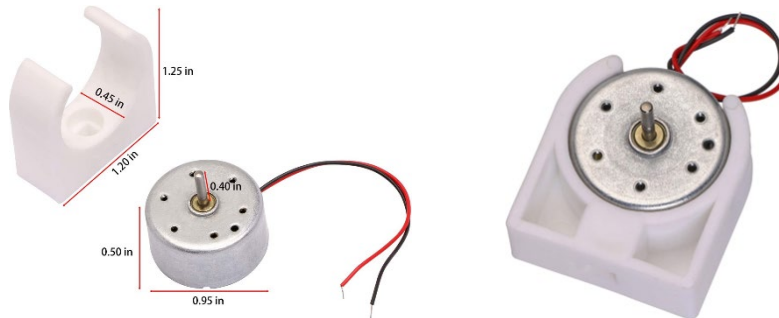

**Figure 6 Small 3V-12V DC motor provided**



- C. The PV panel supplied along with the motor are required elements in the competition as shown in Figure 7.

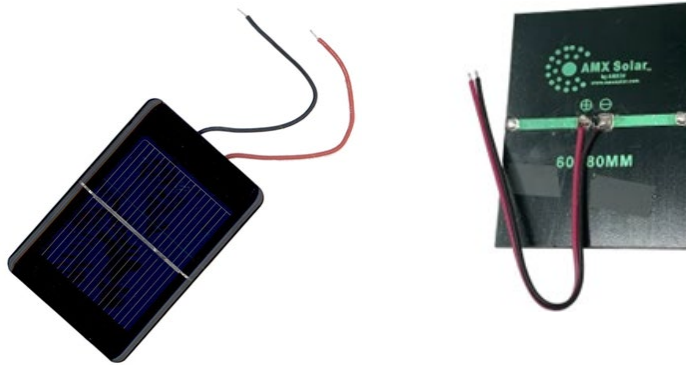

**Figure 7 PV panel(s) provided by CSCA**

- D. Performance considerations for design:

- 1) For maximum speed, the total vessel weight should be minimized.
- 2) The DC motor provided has extremely low torque in the best of sun conditions with the PV panels supplied; and so, performs better at higher RPM with low frictional loads. Designs should consider low hydrodynamic drag and low mechanical friction. Drive gearing or pulleys may be beneficial to increase torque.
- 3) Boat straight-line tracking will reduce repeated contact friction with lane walls.
- 4) PV panel angle, as much as possible, should face the sun. This might involve an adjustable mounting.
- 5) Windage - Because the race is outside, there is a possibility for wind affecting boat speed and direction. Lower freeboard (walls) can reduce windage area.

- E. Developing the design

- 1) Breaking the design into smaller elements is usually beneficial to achieving optimum system results. For example, evaluate separately- the solar power panels mounting and collection, the motor-propulsion, and the vessel floatation stability and tracking can each be tested out separately. Then they can be tested as a system.
- 2) Initially water testing can be performed in a small pool or even indoors by using a 3V battery in place of the solar cell. Remember that the 3V solar panel will produce only a fraction of the power of a 3V watch battery – so that eventually the PV system needs to be tested outside in sunlight.

## **TESTING AND JUDGING**

1. Only one (1) entry (boat assembly) per team will be accepted. A maximum of six people per team will be allowed.

## Engineer It! 2025 Competition Information and Rules

- Two (2) attempts will be allowed for each heat. Note: It is recommended that students test and redesign their device prior to competition day. "It is good engineering practice to plan-design-fabricate-test "and then repeat to optimize."
- Each boat assembly will be visually inspected and measured for compliance with all the rules.
- Once the boat is held against the wall in the starting position, no further adjustments will be permitted until it reaches the end of the lane where it may be manually reversed by the selected team member. These laps are to be repeated until time runs out. Only one person from each team may handle the boat at the ends. The boat direction may be periodically straightened by pushing sideways bumping using the lane lines. The shallow, 6" to 36" deep, pool course is described in Figure 8.

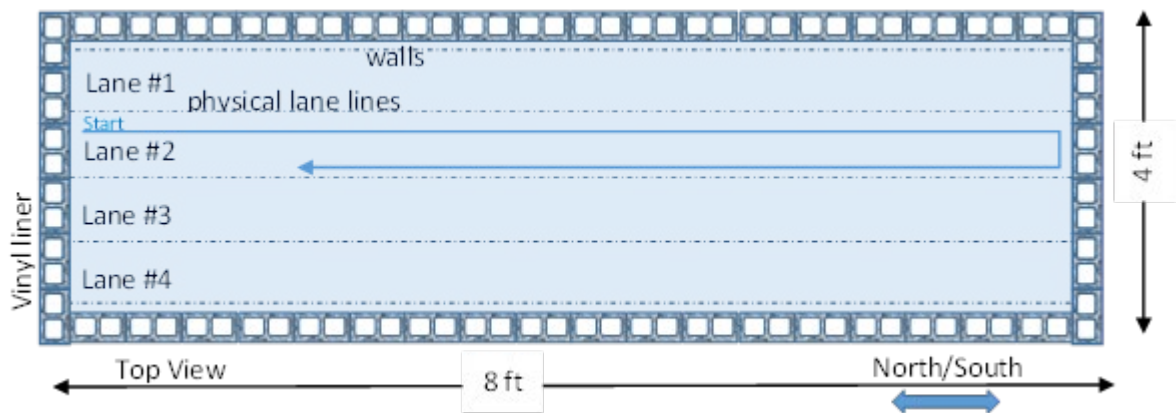

**Figure 8 Fresh-water racecourse schematic diagram**

- The wind velocity will be measured, with time of day and weather noted prior to testing.
- The greatest distance powered over a 5-minute period will be used to create a score for each team.
- In case of a tie in distance a 2-minute run-off will be used as the discriminator.
- The judges will post the results and select the winning watercraft design (Final discretion resides with judges)
- A separate single award will be given to the entry which is deemed to have the most environmentally sustainable construction content. This will be judged based on creative re-use and biodegradable materials in the design.

Example Solar Boat kit(s):

- The Elementary level kit shown in Figure 9 includes a foam boat hull which requires some modification, added features, and assembly to make a competitive entry.

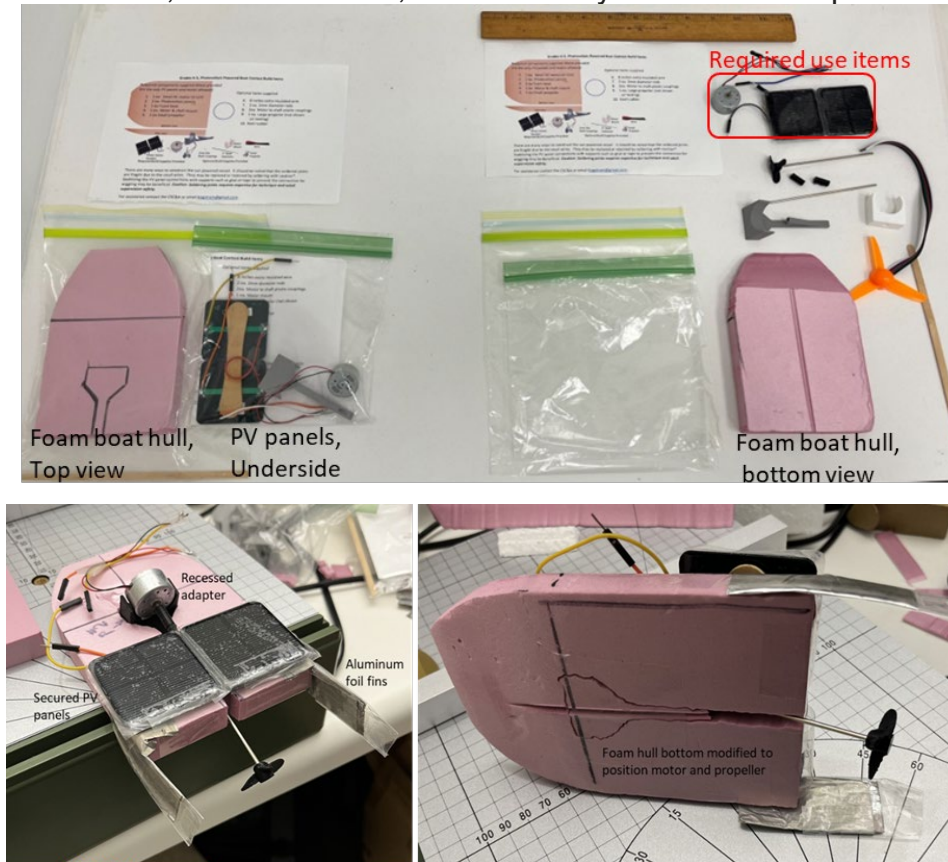

Figure 9 Elementary Solar Boat Kit

- Middle school level kit shown in Figure 10 contains no boat hull but has the plastic motor-driveshaft coupling, along with the pre-soldered pin connectors, which makes things a bit simpler to make a competitive boat.

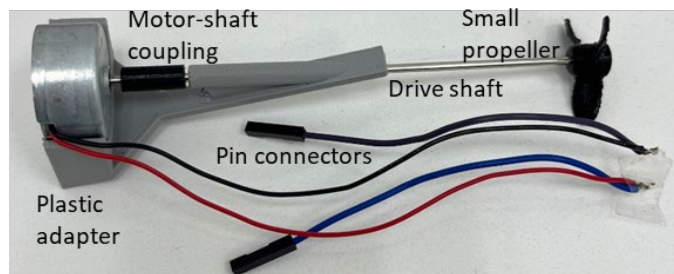

Figure 10 Middle School solar boat kit key features

- HS level kit does not include the foam boat hull, the motor drive shaft coupling, or the pre-soldered connectors between PV panels and motor shown in Figure 1. These components offered to the younger students can be recreated or improved upon to make a better design.